

## LINEDRIVE MULTI-DIM LED DRIVERS

MODELS: LD-XD-UNVxx-12, LD-XD-UNVxx-24

## INSTALLATION INSTRUCTIONS

### GENERAL

These Class 2, electronic, LED drivers are to be installed Indoor in accordance with the National Electric code (NFPA 70) and local regulations. The LED driver must be installed in a well-ventilated area free from explosive gases and vapors. Proper operation requires the free flow of air. Only a qualified electrician should install this hardwired LED driver.

### PRECAUTIONS BEFORE INSTALLING

Check the label and ensure the LED driver has the proper input voltage, output voltage and wattage for the job. Check the wire color to ensure they match the wiring diagram on this instruction sheet.

### MOUNTING

Select a suitable location capable of supporting the weight of the LED driver.

### INPUT CONNECTIONS/GROUNDING

**ATTENTION: Ensure input voltage is 120 or 277VAC.**

Remove the wiring compartment knockouts and install strain reliefs. With power turned off, route the input wires through a strain relief. Connect Neutral, Live and grounding wires to the each of the white, black and green wires from LED driver respectively. The LED driver **MUST** be grounded in accordance with the N.E.C.

### OUTPUT AND DIMMER CONNECTIONS

**Connect Class 2 output power:**

Bring the LED load and dimmer wires through the open knockout. For multiple output drivers, each load must be less than maximum rating for each output.

Connect the LED positive (+) wire to the red wire from LED driver.  
Connect the LED negative (-) wire to the blue wire from LED driver.

**Connect with 0-10V, 10V PWM dimmer:**

Connect the dimmer positive (+) wire to the purple wire from LED driver.  
Connect the dimmer negative (-) wire to the pink wire from LED driver.

**Connect with ELV/MLV/TRIAC dimmer:**

Refer to the dimmer installation and wiring diagram at AC input.

Only one dimmer should be used for proper dimming function.

The 0-10V dimming leads must be disconnected from all other connections and insulated separately when using ELV, TRIAC or MLV dimmers.

**Multi-channel output models:**

Refer to their unit label and specification for each output connection.  
**CAUTION:** Interconnecting the outputs are not permitted.

### QUICK SPECS

<b>Input Voltage</b>	NON-Dimmed or 0-10V Dimmed : 120V / 277V 50/60Hz Phase Dimmed : 120V 60Hz
<b>Dimming</b>	Multi-Dim Technology Line Voltage Phase Dimming: ELV, TRIAC, MLV compatible Low Voltage DC: 0-10V, 10V PWM compatible
<b>Maximum Load</b>	See Model Information chart on page 2. Do not exceed maximum capacity.
<b>Minimum Load</b>	40% (recommended for best performance, capable of lower loads)
<b>Minimum Dim Level</b>	1% (typical, depends on load)
<b>Operating Temp</b>	-40° to 140°F (-40° to 60°C)
<b>Environment</b>	Dry and Damp Location / Indoor
<b>Compliance</b>	cULus Listed, Class 2 FCC Class B

### PARTS INCLUDED:

Constant voltage LED driver wire connectors

### INSTALLATION

#### 1) TURNING OFF POWER



**WARNING: Electric Shock Hazard. May result in serious injury or death.**  
Turn power OFF at circuit breaker prior to installation.

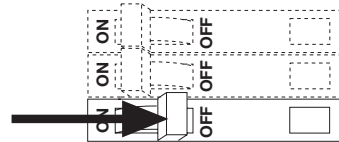

#### 2) INSTALL COMPONENTS

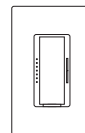

1) Compatible Control

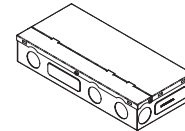

2) LD-XD Series Driver



3) LED Tape Light / Fixture

#### 3) REMOVE WIRING COVER. WIRE DRIVER.

**Remove cover to access wiring compartment.**  
Remove knockouts with hammer and punch.

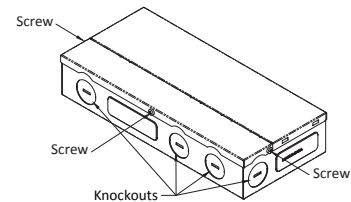

**Attach load and control leads.. Only use copper wiring.**  
Refer to 'System Diagrams', and installation guides.  
Secure cover in place with screws before turning power on.

#### 4) TURN POWER ON AT CIRCUIT BREAKER

Install Additional Components, Verify Connections and turn main power ON at breaker.

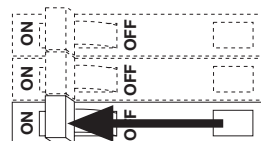

### SYSTEM WORKING IMPROPERLY?

Turn power OFF at circuit breaker and verify all connections.  
Review WIRING and TROUBLESHOOTING

# WIRING DIAGRAMS

The following diagrams are provided as example system designs. Install in accordance with national and local electrical code regulations.

## CONNECT WITH ELV/MLV/TRIAC DIMMER (120VAC INPUT ONLY)

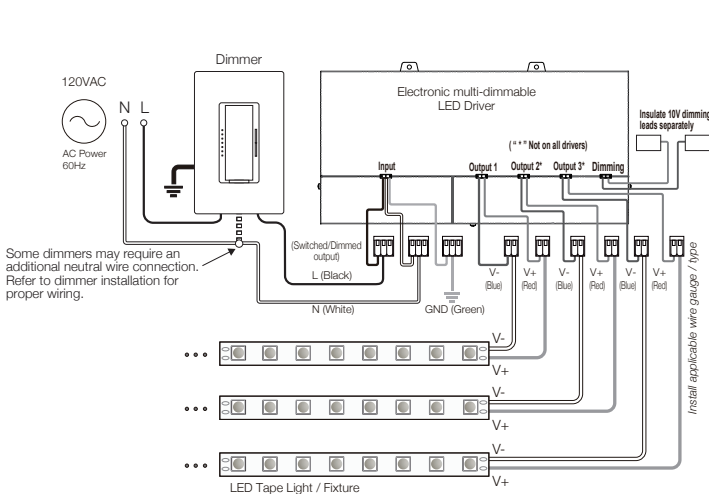

## CONNECT WITH 0-10V, 10V PWM DIMMER (120/277VAC INPUT)

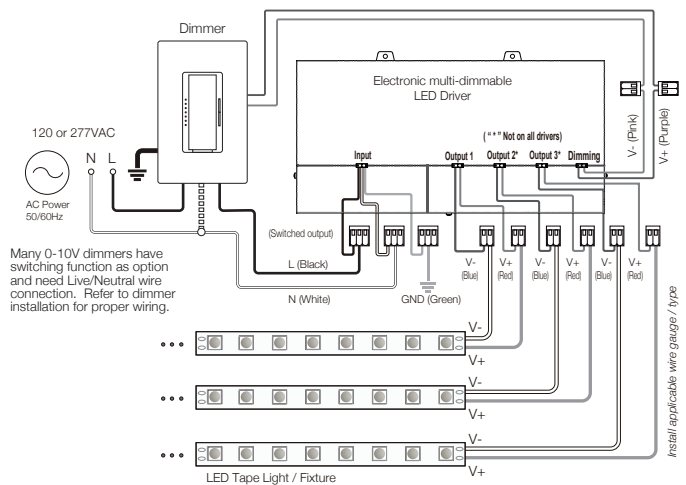

See LED load specifications for maximum series run limits.  
Be sure to match driver output voltage to load voltage.

**\* CAUTION:** Do not connect output leads together for drivers with 2 or 3 sets of outputs. Keep each set of output leads separated.

# MODEL INFORMATION

Model	Output Volts/Max Watts	Size (L x W x H)	Weight (lbs.)
LD-XD-UNV20-12	12V / 20W	7.93" x 3.36" x 1.33"	1.87
LD-XD-UNV20-24	24V / 20W	7.93" x 3.36" x 1.33"	1.87
LD-XD-UNV40-12	12V / 40W	7.93" x 3.36" x 1.33"	1.87
LD-XD-UNV40-24	24V / 40W	7.93" x 3.36" x 1.33"	1.87
LD-XD-UNV60-12	12V / 60W	8.29" x 4.10" x 1.59"	2.2
LD-XD-UNV60-24	24V / 60W	8.29" x 4.10" x 1.59"	2.2
LD-XD-UNV96-24	24V / 96W	8.29" x 4.10" x 1.59"	2.2
LD-XD-UNV180-12	12V / 3 x 60W	9.51" x 6.35" x 1.59"	4.4
LD-XD-UNV200-24	24V / 2 x 96W	9.51" x 6.35" x 1.59"	4.4
LD-XD-UNV300-24	24V / 3 x 96W	9.51" x 6.35" x 1.59"	4.4

# TROUBLESHOOTING

Prior to troubleshooting, ensure all items are a compatible system and main power is turned ON.

<b>Fixture does not illuminate</b>	<ul style="list-style-type: none"> <li>See 'Wiring Diagrams' and installation guides of all components.</li> <li>Ensure the system is wired correctly and polarities are correct.</li> <li>Ensure the driver and fixture have the same voltage specifications.</li> </ul>
<b>Fixture is flashing or flickering</b>	<ul style="list-style-type: none"> <li>Ensure all fixtures have the same operating voltage as the driver output.</li> <li>Ensure all connections are properly secured.</li> <li>Ensure driver is not overloaded. An overloaded driver will cause the internal auto-reset to trip repeatedly.</li> <li>Ensure each output channel connected properly. No interconnection for outputs</li> </ul>
<b>Fixture does not dim</b>	<ul style="list-style-type: none"> <li>Ensure a compatible constant voltage dimmable fixture is installed.</li> <li>Ensure a compatible dimming control is installed and wired correctly.</li> </ul>
<b>Different fixture types do not dim in sync</b>	<ul style="list-style-type: none"> <li>Different fixture types have different circuit designs and may react differently when dimmed. Ensure each fixture type is installed on a separate dimmable power supply for best performance.</li> </ul>
<b>Installation Trips Main Breaker</b>	<ul style="list-style-type: none"> <li>Check wiring for short circuit. If breaker continues to trip there may be a short in the driver. Call customer support for a replacement driver.</li> <li>Check AFCI for faults.</li> <li>Check for neutral or ground faults.</li> </ul>