



WARNING!

BEFORE YOU START:

- Please check local electrical codes before beginning
- Turn power off before installing
- Make sure to use properly rated wire

TOOLS NEEDED:

- Gloves
- Metal Shears
- Screwdriver
- Drywall Screws
- Drywall Cutting Tool and Bits or Drywall Hand Saw

PARTS INCLUDED:

- New Construction Mounting Plate
- Screws

NOTE: WE RECOMMEND THAT YOU ENGAGE A QUALIFIED AND LICENSED ELECTRICIAN.

MOUNT AND CONNECT FIXTURE DRIVER AND POWER SUPPLY PER INSTRUCTIONS THAT COME WITH THAT UNIT.

1. Familiarize yourself with the mounting plate with particular attention to the mounting ring cut-outs and the fixtures that they correspond to. Refer to Table (FIG. 1 and FIG. 2) Follow instructions for preparation and wiring for the fixture selected. **CAUTION: Space behind location of downlight must be clear of building materials and electrical components.**

2. CUT-OUT MOUNTING APERTURE IN MOUNTING PLATE:

Select color temperature of light source. You'll find the color temp. selector switch on the side of the junction box. Find your fixture in the table for a specific mounting plate. Find the ring diameter required to mount your fixture. Remove inner rings that are not needed with sheet metal shears. **THERE ARE SHARP EDGES ON MOUNTING PLATE. WHENEVER HOLDING PLATE, WEAR GLOVES (FIG. 3).**

3. INSTALLING MOUNTING PLATE AND PREPARING THE CEILING: Place plate in desired position and screw into ceiling joists (FIG. 4). Install incoming electrical power connections for fixture power supplies. See instructions for specific fixtures to set possible options like color temperature or power settings before installing power supply in ceiling space. Install (where applicable) integral power supply, driver or wiring compartment onto mounting plate where indicated.

Install drywall over mounting plates. Use a stud finder to locate hole plate opening for fixture. Use a hole saw to cut along the plate hole edge to create the ceiling hole. Paint and finish drywall. (FIG. 5).

4. MOUNT FIXTURE: Find power supply cable and connect to downlight. Install fixture per instructions specific to each fixture. (FIG. 6).

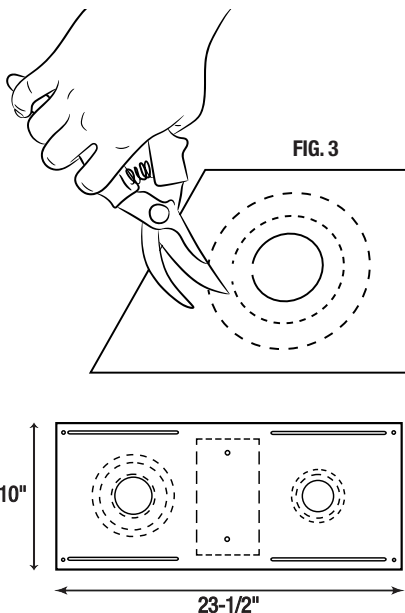

FIG. 3

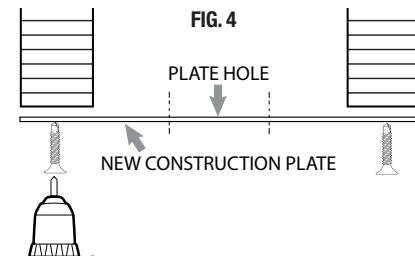

FIG. 4

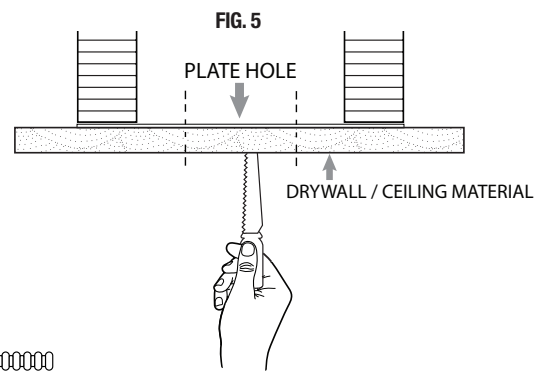

FIG. 5

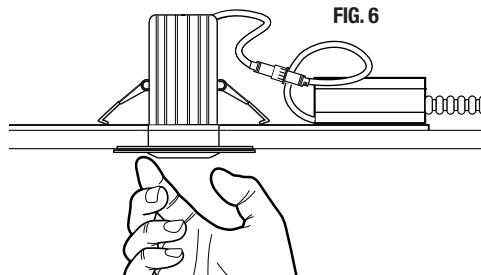

FIG. 6

UNV-NCP

FIG. 1

FIXTURE	CUT-OUT DIMENSION
MDL-3R	2-3/4" Dia.
MDL-3S	2-3/4" Dia.
MDL-3AR	2-3/4" Dia.
MDL-4R	3-3/4" Dia.
MDL-4S	3-3/4" Dia.
MDL-4AR	4-1/4" Dia.
RSD-3	3-1/4" Dia.
RSD-4	4-1/4" Dia.
RSD-6	6-1/4" Dia.
RSD-8	8-1/4" Dia.

CHDL-UNV-NCP

FIG. 2

FIXTURE	CUT-OUT DIMENSION
MTR1-5CCT	2-1/8" Dia.
MTS1-5CCT	2-1/8" Dia.
MTRA1-5CCT	2-1/8" Dia.
MTST2-5CCT	2-13/16" x 2-13/16" Sq.
MTR2-5CCT	2-5/8" Dia.
MTS2-5CCT	2-5/8" Dia.
MTRA2-5CCT	2-5/8" Dia.
MTRT2-5CCT	2-5/8" Dia.
MTRAT2-5CCT	3-1/8" Dia.
CHDL-4	4-3/4" Dia.
CHDL-6	5-3/4" Dia.